

Overview of High Performance Analog Optocouplers

Application Note 1357

Designing Analog Circuits Using the HCNR201

Internally, the HCNR201 analog optocoupler consists of two photo detectors symmetrically placed between the input LED. Thus, the radiant flux received by each of the two photodetectors is essentially the same, and forms the basis for the input-output linear transfer response. Unlike most other optocouplers, where the LED at the input is directly controlled, for the HCNR201 the input photodetector is generally placed in a servo feedback loop to control the LED current through the use of an external op-amp. This feedback loop has the most advantageous effect of compensating for any temperature related light output drift characteristics or other nonlinearities or aging effects of the LED.

Figure 1 shows the basic topology using the HCNR201 in the servo feedback loop. The HCNR201 is connected in a photovoltaic mode, as the voltage across the photo-diodes is essentially zero volt. For a photoconductive operation the photo-diodes are reverse biased as shown in Figure 2.

The two op-amps shown are two separate LM158 packages, and not two channels in a single dual package, otherwise galvanic

insulation is not present as the grounds and Vcc are shared between the two op-amps of the dual package. The op-amp always tries to maintain the same inputs voltages at its two inputs in a linear feedback close loop connection. Thus, the input side op-amp always tries to place zero volts across the photodiode 1 (PD1). As noted before, in the

photo-voltaic mode of operation, the photodiode has either a forward bias or no bias applied across it. Thus, when the $V_{in}=0V$, there is no photodiode 1 current (I_{PD1}) and so also is the I_{PD2} zero. This is because $I_{PD2} = K_3 \times I_{PD1}$ by the transfer gain K_3 indicated in the data sheet ($K_3 = I_{PD2}/I_{PD1} = 1$). Now, if some positive polarity voltage is applied at the input,

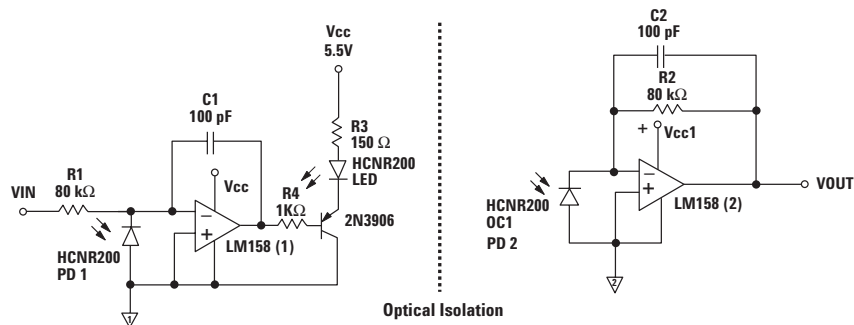

Figure 1. Positive Polarity Input Voltage Analog Isolation Amplifier using the HCNR201 in Photo-Voltaic Mode

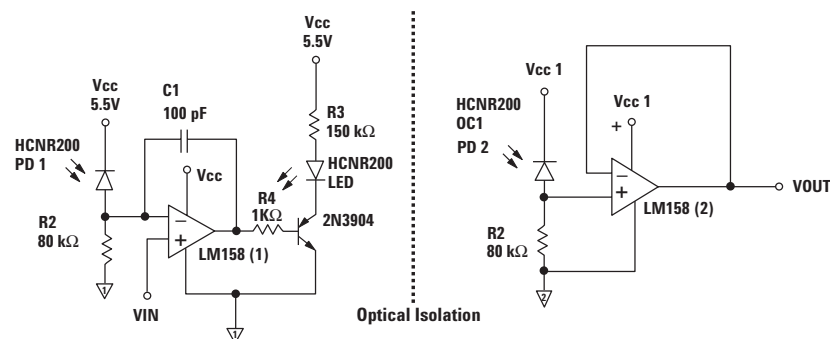

Figure 2. Positive Polarity Input Voltage Analog Isolation Amplifier using the HCNR201 in Photo-Conductive Mode

the op-amp output would tend to swing to the negative rail (in this case the ground voltage) causing the LED current to flow. The I_{PD1} is now externally set by V_{IN} and R_1 ($I_{PD1} = V_{IN}/R_1$). The op-amp will limit the LED current I_F to an appropriate value required to establish the externally set I_{PD1} . The maximum full scale LED current is designed to keep it under the absolute max rating of 25 mA. Since, the op-amp is connected in a stable negative feedback servo loop it is also maintaining the same voltages across its two inputs, in this case zero volts. The output voltage is just $I_{PD2} \times R_2$. Thus, to establish the transfer function following equations can be written:

$$I_{PD1} = V_{IN}/R_1$$

(input photo-diode current)

$$K_3 = I_{PD2}/I_{PD1} = 1$$

(transfer gain indicated in the data sheet)

$$I_{PD2} = K_3 \times I_{PD1}$$

$$V_{OUT} = I_{PD2} \times R_2$$

Solving the above equations readily yields the linear transfer function as $V_{OUT}/V_{IN} = K_3 \times R_2/R_1$

Typically, the transfer gain $K_3 = 1$, and is $\pm 5\%$ for the HCNR201 and $\pm 15\%$ for the HCNR200. The input photo gain is represented by K_1 parameter in the data sheet and is defined as I_{PD1}/I_F . The data sheet for the HCNR201 lists this input current transfer ratio as (0.25 to 0.75)% for HCNR200 and (0.36 to 0.72)% for the HCNR201. As indicated in the data sheet for best linearity the photo-diode current is constrained between 5 nA to 50 μ A. This implies that the V_{in} and R_1 combination at the input should constrain the externally set maximum photodetector current at 50 μ A. However, higher photo-detector currents up to 100 μ A can be easily set at higher LED currents close to 25 mA.

Figure 2 shows the HCNR201 biased in a photo-conductive mode of operation, where the photo-diodes are forced into reverse bias. In reverse bias the photo-diode capacitance is lower as the depletion regions are larger. Thus, for higher bandwidth response it may be advantageous to use the photo-conductive configuration. The equations to derive the transfer function are similar to the photo-voltaic mode discussed earlier.

With R_1 at 80 kohm an input voltage maximum of 4 volts will keep the maximum photo-diode current at 50 μ A to achieve the linearity indicated in the data sheet of the HCNR201. As noted before photo-diode currents up to 100 μ A or higher can be easily set if so desired.

Bipolar Input Voltage Analog Circuit

Using similar concepts as developed for the positive-polarity input voltage analog amplifier discussed before, it is quite straightforward to develop bipolar input voltage analog amplifier. Figure 3 shows the bipolar input voltage analog circuit using the HCNR201 in the servo feedback loop.

This bipolar input voltage circuit uses two HCNR200 or HCNR201 optocouplers. The top half of the circuit consisting of PD1, R1, DA, C1, R4 and optocoupler 1 (OC1) LED is for the positive input voltages. The lower half of the circuit consisting of optocoupler 2 (OC2) PD1, R2, BB and R5 and optocoupler 2 (OC2) LED is for the negative input voltages.

The diodes D1 and D2 help reduce crossover distortion by keeping both amplifiers active

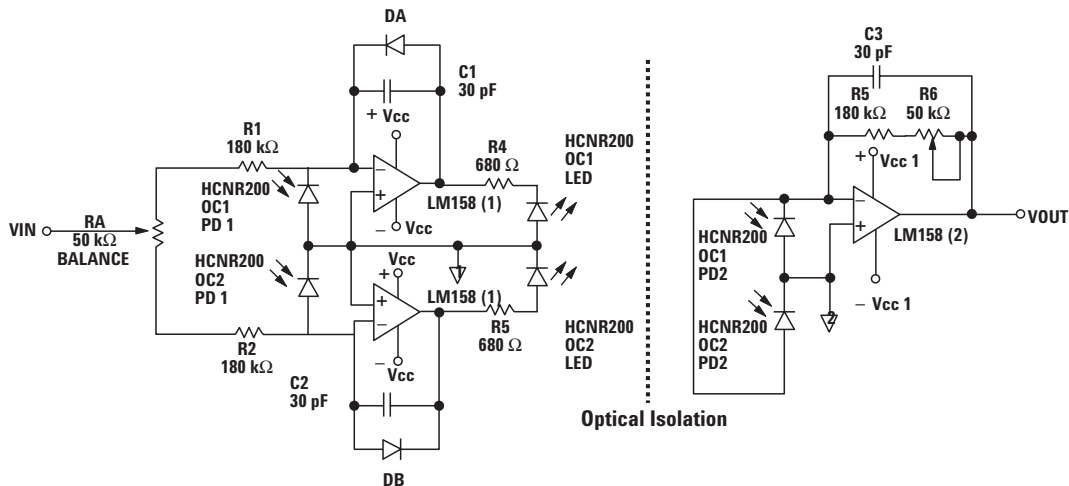

Figure 3. Bipolar Input Voltage Analog Isolation Amplifier using the HCR201

during both positive and negative portions of the input signal. Balance control R1 at the input can be used to adjust the relative gain for the positive and negative input voltages. The gain control R7 can be used to adjust the overall transfer gain of the amplifier. The capacitors C1, C2, and C3 are the compensation capacitors for stability.

Current to Voltage Converter

For measurement of very small currents such as transducer sensor currents, a simple analog current-to-voltage circuit can be designed as shown in Figure 4. This circuit uses two HCNR200 optocouplers. The input current can be of either polarity. The upper limit for the I_{IN} should be constrained to 50 μA maximum to achieve the non-linearity specifications of 0.05% indicated in the data sheet.

The lower limit of the current measurement depends upon the maximum dark current associated with the photodiodes, which are approximately in the neighborhood of 100 pA maximum over temperature. The two HCNR200 devices in this configuration are essentially connected in anti-parallel configuration. One HCNR200 then translates the positive input current to a positive voltage. The second HCNR200 translates the negative current into a negative output voltage.

The resistor R2 is chosen to give the full scale output voltage as:

$V_{out} = \pm I_{IN} R_2 = \text{full scale output voltage}$. Thus R2 would be 100 kohm at 50 μA max input current for a full-scale output voltage of 5V. Photo diode currents up to 100 μA or higher can also be easily selected.

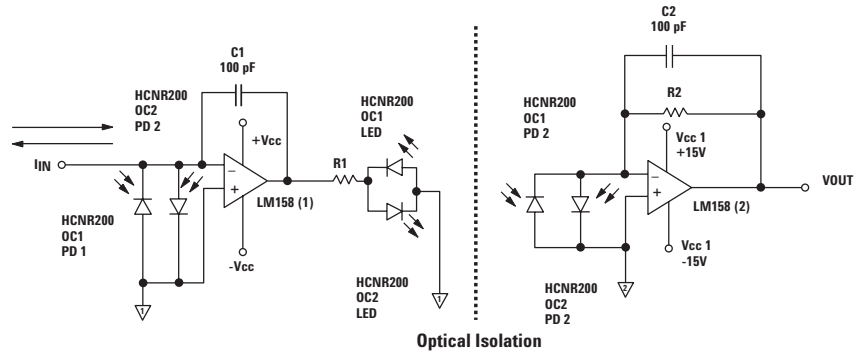

Figure 4. Current-to-Voltage Converter using the HCNR200

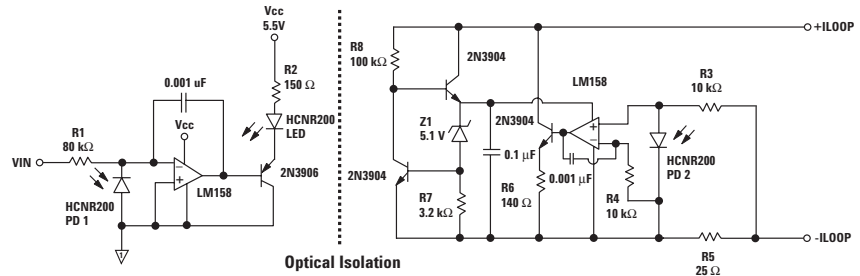

Figure 5. Isolated 4-to-20 mA Analog Transmitter circuit using the HCNR200

Isolated 4-to-20 mA Analog Transmitter Circuit

Industrial manufacturing environments very often require measuring temperatures, pressures, or fluid levels in a harsh electrically noisy environment. Transmitting signals through current instead of voltage could be advantageous in such an environment. Very often the distance between the sensor stage to a controller, typically a PLC or a microcontroller could also be a sizeable distance. Additional requirement in such an application could be for high voltage insulation or galvanic insulation for safety protection either of operators or expensive digital logic. Both of these critical requirements can be easily addressed through the use of optically isolated 4 to 20 mA transmitter and receiver circuits.

Figure 5 shows a 4-to-20 mA analog transmitter circuit designed around the HCNR201.

A unique feature of this circuit is that there is no need for an isolated power supply on the loop side of the optical circuit. The loop current generator supplies the power supply voltage. The zener Z1 establishes the voltage required by loop-side op-amp. To establish the transfer function, following equations are established:

$$I_{PD1} = V_{IN}/R_1$$

$$K_3 = I_{PD2}/I_{PD1} = 1$$

(by the transfer gain indicated in the data sheet)

The current division at the intersection of R_5 , R_4 , and R_3 establishes the photo-diode current (I_{PD2}) portion of the loop current. The resistors R_3 and R_5 are essentially in parallel and form the actual current divider. Thus, I_{PD2} can be written as

$$I_{PD2} = I_{LOOP} \cdot (R_5 / (R_5 + R_3))$$

Solving these equations yields the transfer function as

$$K_3 \cdot V_{IN}/R_1 = I_{LOOP} \cdot (R_5/(R_5 + R_3))$$

$$I_{LOOP}/V_{IN} = K_3 \cdot (R_5 + R_3)/(R_5 R_1)$$

The resistor values have been so selected in this example that when input voltage is 0.8 V the loop current formed is 4 mA, and when the input voltage is 4 V, the loop current formed is 20 mA. This assumes that the transfer function K_3 equals 1, which is the case typically as indicated in the data sheet for the HCNR201.

Isolated 4-to-20 mA Analog Receiver Circuit

The 4-to-20 mA receiver circuit is similar in construction to the 4-to-20 mA transmitter circuit discussed earlier. In the receiver case, the loop current is received at the input of the receiver, and the output is a linear voltage representation of the input loop current. Figure 6 shows the receiver circuit.

Once again, no isolated power supply is needed on the loop side of the receiver circuit, as the power supply is established by the source supplying the loop current. The zener Z_1 establishes the 5 V level for the Op-amp power supply. The loop current is split at the junction of R_3 and R_2 and PD₁. The resistors R_1 and R_3 are essentially in parallel, as there is zero volts across the photo-detector diode (PD₁). The servo op-amps forces zero volts across the PD₁, and thus R_1 and R_3 form the current divider for the loop current.

The transfer function for the receiver circuit can be established by observing the following equations

$$I_{PD1} = I_{LOOP} \cdot (R_3/(R_3 + R_1))$$

$$K_3 = I_{PD2}/I_{PD1}$$

$$V_{OUT} = I_{PD2} \cdot R_5$$

Solving these equations leads us to the transfer function as

$$V_{OUT}/R_5 = K_3 \cdot I_{LOOP} \cdot (R_3/(R_3 + R_1))$$

$$V_{OUT}/I_{LOOP} = K_3 \cdot R_5 \cdot R_3/(R_3 + R_1)$$

The resistor values shown in the receiver circuit are scaled such that when loop current is 4 mA the output voltage is 0.8V. When the loop current is 20 mA the output voltage is 4V. This again assumes that K_3 (transfer function) equals 1 which is typically the case as indicated in the data sheet for the HCNR201.

Wide Bandwidth Video Analog Amplifier

For wide-bandwidth video analog applications an amplifier design is shown in Figure 7. This is an ac input coupled and ac output coupled circuit. The LED input current I_F is set at a recommended 6 mA for the HCPL-4562 or 10 mA for the HCNW4562 by selecting an appropriate value for the R_4 . If the V_{CC1} on the input side is 5V the voltage V_B established by the resistor divider R_1 and R_2 at the base of Q_1 (neglecting base current drop across R_3) is approx. 1.16V. This establishes the voltage V_E at the emitter of Q_1 as 0.56V. Adjust R_4 to set the recommended LED current at 6 mA.

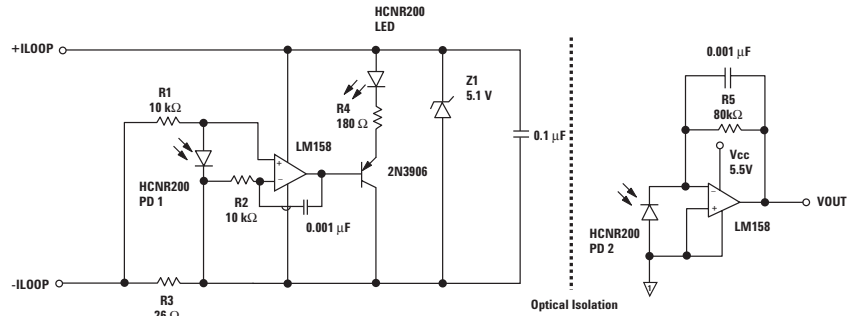

Figure 6. Isolated 4-to-20 mA Analog Receiver Circuit using the HCNR200.

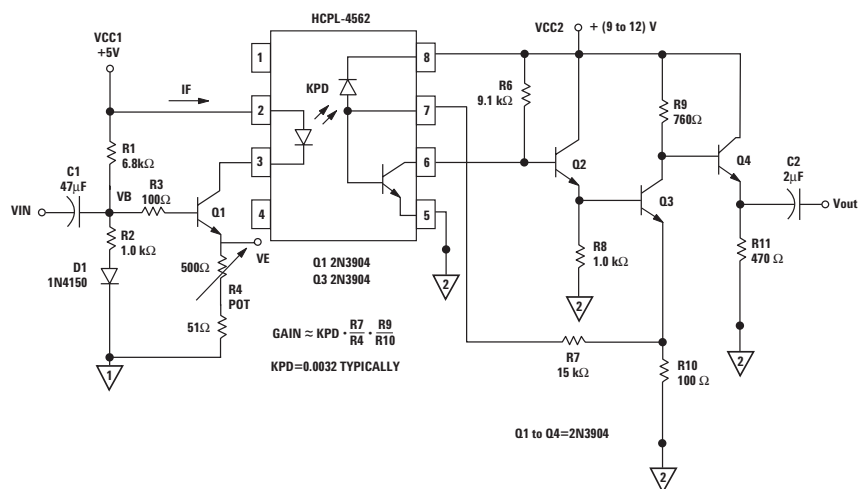

Figure 7. Wide Bandwidth Analog Isolation Amplifier Using the HCPL-4562.

With 0.56V at V_E the resistor R4 is selected to be approx. 93Ω for 6 mA of I_F .

With a V_{CC2} supply between (9 to 12) V, the value of R_{11} is selected to keep the output voltage at mid-point of the supply at approx. 4.25V with the collector current I_{CQ4} of Q_4 at approx. 9 mA.

Where R_{11} , is the parallel combination of R11 and load impedance and f_{T4} is the unity gain frequency Q_4 . From this equation one can observe that to maximize the bandwidth one would want to increase the value of R_{11} , or reduce the value of R_9 at a constant ratio of R_9/R_{10} .

$$I_{CQ4} \leq 4.25V/470\Omega \leq 9 \text{ mA}$$

The small signal model of the bipolar transistors can determine the overall voltage gain of the circuit and gain stages involved and is found to be

$$G_V \approx V_{OUT}/V_{IN} \approx \partial I_{PB}/\partial I_F [R_7 R_9 / R_4 R_{10}]$$

Where $\partial I_{PB}/\partial I_F$ is the base photo current gain (photo diode current gain) and is indicated as a typical of 0.0032 in the data sheet. Adjust resistor R_4 to achieve the desired voltage gain. The voltage gain of the second stage (Q_3) is approximately equal to

$$R_9 / R_{10} \cdot / [1 + sR_9 (C_{CQ3} + 1/(2\pi R_{11} f_{T4}))]$$

Optically Coupled Regenerative Audio Receiver

A simple optically coupled regenerative (OCR) RF audio receiver can be constructed using the HCPL-4562 where the tuning control and regenerative control are optically isolated from the rest of the receiver circuit.² Figure 8 shows one such regenerative detector design, where the RF from the antenna is optically

cally coupled to the base of the oscillator transistor.

In this design the optocoupler's transistor is configured as a Colpitt's oscillator. The base current that controls the oscillation of the optocoupler output transistor (Q_1) is supplied by the optical photon coupling from the input LED I_F modulation. The RF energy from the antenna is coupled to the LED by the tuned circuit formed by T_1 and C_1 . The 10kohm potentiometer provides the regeneration control at the input of the LED.

It is possible to connect an audio transformer directly in the collector circuit of Q_1 to drive the high sensitivity and high impedance headphones. However, in the design shown in Figure 8 the audio is recovered by a high impedance MOSFET transistor Q_2 . The tuned circuit (L_1 , C_2) is connected to the gate of this infinite

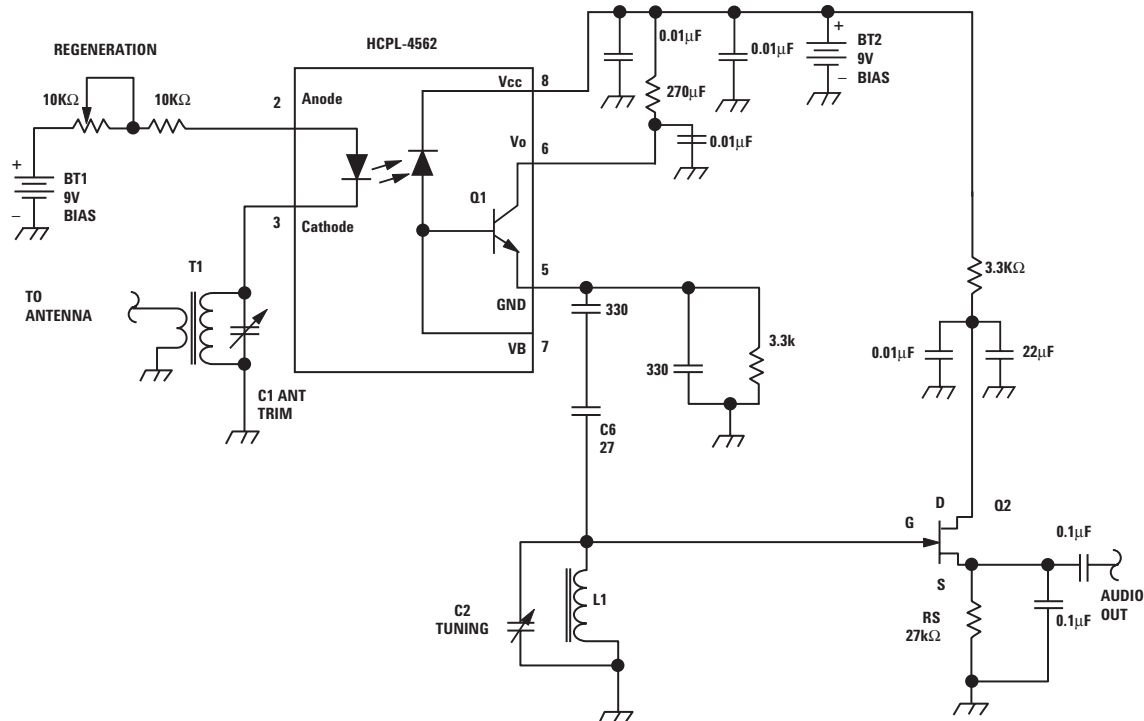

Figure 8. Optically Coupled Regenerative Audio Receiver.

impedance MOSFET transistor Q2 which has a minimal loading impact on the tuned circuit. The audio voltage is developed across R_S (27 kohm). The simple RC filter formed by R_S and 0.1 μ F capacitor filters out the RF component and passes the audio component for the headphones. If necessary, one can connect an additional amplification stage, along with further filtering, and an audio amplifier at the output to drive low impedance headphones.

Agilent's Isolation Amplifiers

Optical isolation boundary in Isolation Amplifiers provides high common mode rejection capability. Sigma-Delta modulation and unique encoding/decoding technologies provide high precision and stability performance. All above performances rely on an integrated high-speed digital optocoupler to transmit signal across isolation boundary. Figure 9 is the functional block diagram. HCPL-788J integrates short circuit and overload detection contributed to intelligent motor driver.

A 2nd order Σ - Δ modulator converts analog input signal into single bit data stream, which is edge-triggered by encoder. High speed encoded data transmit through optical coupling channel, and is recovered to single bit stream by decoder. The digital-to-analog converter simply converts single bit stream into very precise analog voltage levels. The final analog output voltage is recovered by filtering the DAC output. The filter was designed to maximize bandwidth while minimizing quantization noise generated by the sigma-delta conversion process. The overall gain of the isolation amplifier is determined primarily by matched internal temperature-compensated bandgap voltage references, resulting in very stable gain characteristics over time and temperature.

The typical performance such as offset, gain tolerance, nonlinearity and temperature drift can be guaranteed by differential output manner. One external op-amp has three functions: to reference the output

signal to the desired level (usually ground), to amplify the signal to appropriate levels, and to help filter output noise.

Single-pole output from isolation amplifier, like V_{OUT+} to GND2, can be used to save cost by less op-amp and a few other components.

Absolute output from smart amplifier HCPL-788J is usually used to monitor AC current value, regardless of polar of the current. Absolute output can directly connect to microcontroller and simplify the design of output signal circuit.

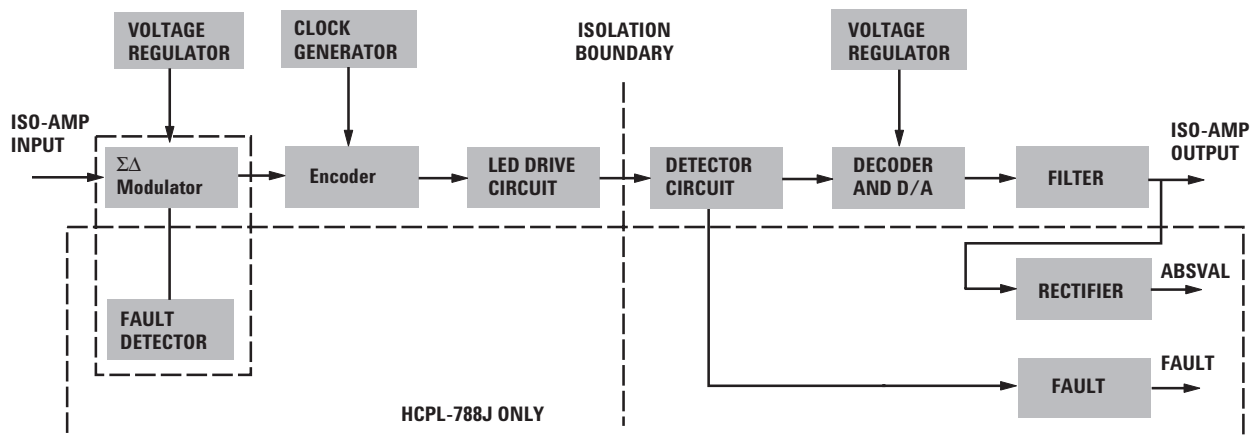

Figure 9. HCPL-7800/7840/788J Block Diagram.

Shown in Figure 10, isolated modulator HCPL-7860/786J has direct Sigma-Delta signal output with modulation clock, which can be directly connected to microprocessor and converted to 12-bit effective resolution digital data.

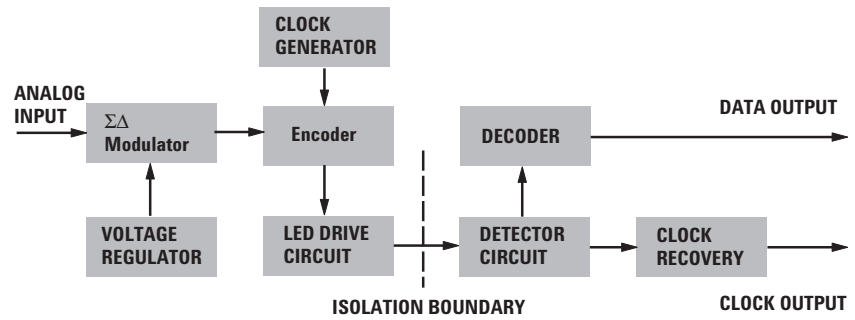

Figure 10. HCPL-7860/786J Block Diagram.

Table 1. Specifications Overview of Isolation Amplifiers.

Isolated Amplifier, HCPL-	7800	7800A	7840	788J
Gain Tolerance, %	±3	±1	±5	±5
Max. Input Offset Voltage, mV	3	3	3	3
Max. Input Offset Drift Vs Temperature, mV/°C	10	10	10	10
V _{OUT} 100 mV Max. Nonlinearity, %	0.2	0.2	0.2	0.4
Typ. Gain Drift Vs Temperature, ppm/°C	250	250	250	50
Max. Prop Delay, ms	9.9	9.9	9.9	20
Min. CMR at V _{CM} = 1 kV, kV/ms	10	10	10	10
Package Type	DIP8	DIP8	DIP8	S016
IEC/EN/DIN EN 60747-5-2 [V _{IORM}], V _{PEAK}	891 ^[1]	891 ^[1]	891 ^[1]	891 ^[1]
UL [V _{ISO}], V _{RMS}	3750	3750	3750	3750

Isolated Modulator, HCPL-	7860	786J
Max. Offset Drift Vs. Temperature, mV/°C	10	10
Max. Internal Reference Voltage Matching Tolerance, %	1	2
Min. CMR at V _{CM} = 1 kV, kV/ms	15	15
Package Type	DIP8	S016
IEC/EN/DIN EN 60747-5-2 [V _{IORM}], V _{PEAK}	891 ^[1]	891 ^[1]
UL [V _{ISO}], V _{RMS}	3750	3750

Note:

- Option 060 is needed

General Voltage Sensing

With Agilent's isolation amplifiers, a designer can simply eliminate extra noise affection when sensing AC or DC voltage. A high voltage source V_s (Figure 11) is divided by resistors R_s and R_1 to get a typical voltage signal ± 200 mV from formula:

$$V_{in} = V_s R_s / (R_s + R_1)$$

R_s value should be relatively small to match with isolation amplifier's input impedance, and to keep a relative bias current which does not affect the accuracy of measurement. For example, HCPL-7840 input impedance 500 k Ω and a less than 1 k Ω R_s will have 0.4 μ A peak bias current.

A capacitor C_1 is connected as low-pass filter to prevent isolation amplifier from voltage transients of input signal. To obtain higher bandwidth, the capacitor C_1 can be reduced, but it should not be reduced much below 1000 pF to maintain gain accuracy of the isolation amplifier.

Single-pole output between V_{OUT+} to GND2 is usually applied for general voltage sensing for saving cost.

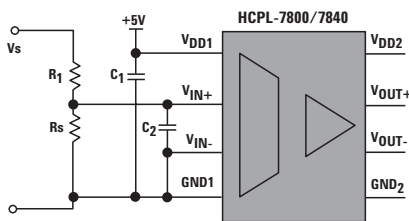

Figure 11. General Voltage Sensing Circuit.

General Current Sensing

A large current source can be sensed by a shunt resistor R_s , which converted current to a voltage signal $V_{in} = I_s R_s$ (Figure 12).

For example, to monitor a single phase 240 VAC/1.2 kW lamp current, its peak current is:

$$I_s = \pm(5 \cdot 1.414) \text{ A} = \pm 7.07 \text{ A}$$

R_s is calculated at 28 m Ω while the peak current input voltage are ± 198 mV. This resistor results a power dissipation less than 1/4 W.

The power supply V_{DD1} in input side of optocoupler can be available from rectified and regulated AC line, but the output side power supply V_{DD1} must be isolated to AC line.

A 39 Ω resistor R_1 and bypass capacitor C_2 are connected to filter voltage transients from input signal.

Single-pole output between V_{OUT+} to GND2 is usually applied for general current sensing for saving cost.

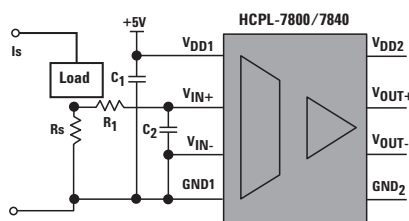

Figure 12. General Current Sensing Circuit.

Motor Current Sensing

Inverter or servo motor drivers implement vector control fast and accurately with two modern control loops: position feedback by optical encoder and current feedback by optical isolated amplifier.

Optical isolated amplifiers directly measure phases or rail current, replacing conventional indirect measurement through transformer or Hall Effect sensor. The users had recognized significant advantages of optocouplers: standard IC package, high linearity, low temperature draft. These features provide opportunities to make a compact, precise and reliable motor driver.

A typical application circuit in Figure 13 mainly consists of shunt resistor, isolated amplifier and a low cost op-amp.

The maximum shunt resistance R_s can be calculated by taking the maximum recommended input voltage and dividing by the peak current that should see during normal operation. For example, if a motor will have a maximum RMS current of 30 A and can experience up to 50% overloads during normal operation, then the peak current is 63.3 A ($= 30 \cdot 1.414 \cdot 1.5$).

Assuming a maximum input voltage of 200 mV, the maximum value of shunt resistance in this case would be about 30 m Ω .

The particular op-amp used in the post-amp circuit is not critical. However, it should have low enough offset and high enough bandwidth and slew rate so that it does not adversely affect circuit performance. The gain is determined by resistors R_4 through R_7 , assuming that $R_4 = R_5$ and $R_6 = R_7$, the gain of the post-amplifier is R_6/R_4 .

Bootstrap power supply is usually used to reduce cost and size in motor driver. It eliminates the need for an isolated power supply or a dc-dc converter. A bootstrap power supply for high side of a half bridge is shown in Figure 5, When designing a bootstrap power supply, the bootstrap components R_1 , R_2 , C_1 and C_2 must be chosen to sufficiently power its load—the isolated half side of gate drive and current sensing optocouplers.

When low IGBT is on, rail voltage goes through R_1 , R_2 and C_1 to charge capacitor C_2 up to 18 V and meanwhile supply to HCPL-3120 and regulator, which powers current sensor. When low IGBT is off, C_2 discharges and distributes its current to gate driver and regulator 78L05. The threshold voltage of bootstrap power supply is 15 V, which is required by gate driver HCPL-3120.

When low IGBT is off, the stored energy on C_1 will discharge to C_5 , which are together with D_{Z2} to generate a negative voltage source.

A bootstrap power supply for low side of half bridge is identical to high side circuit.

Conclusion

This paper has outlined and highlighted the wide scope and applications that are now possible using sophisticated and highly linear optocouplers. Designers can now choose and select an appropriate analog optocoupler available from Agilent Technologies, Inc. that meets their end analog design criteria. This includes high common mode rejection capable current or voltage sensing optocouplers such as the HCPL-7800A or the HCPL-788J. Or the high linearity optocouplers such as the HCNR201. Or the high bandwidth optocouplers such as the HCPL-4562.

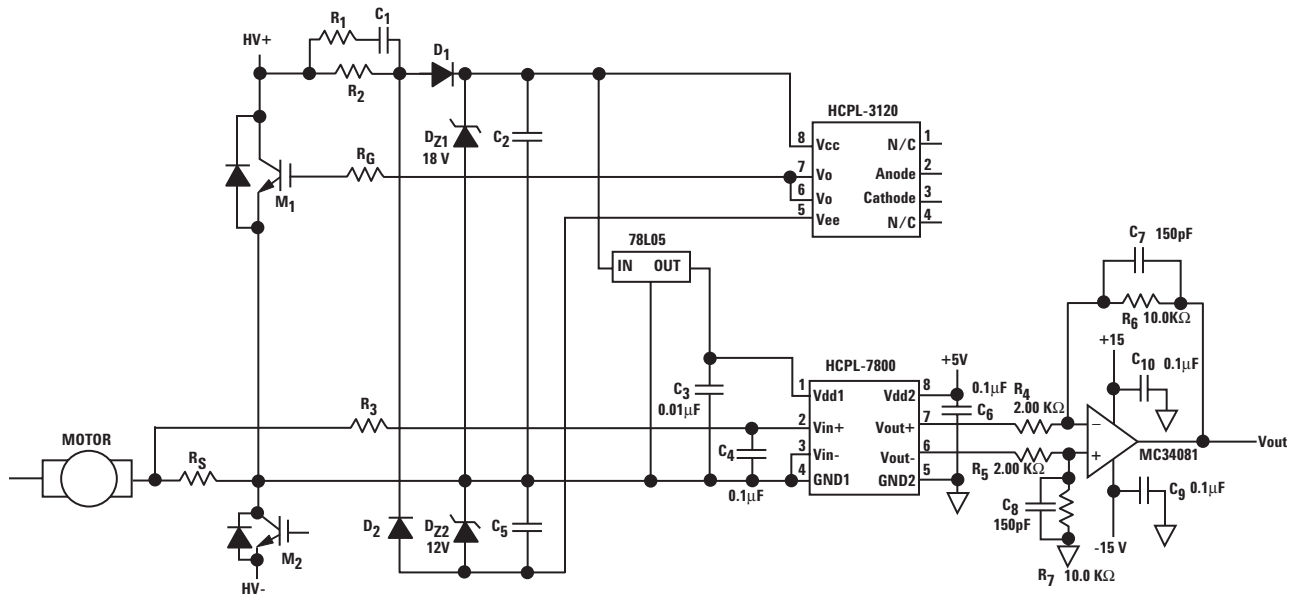

Figure 13. Motor Current Sensing Circuit.

References

1. *Photodiode Amplifiers: Op Amp Solutions*, Jerald G. Graeme, McGraw-Hill, New York, 1996.
2. "The OCR Receiver," QST, Daniel Wissell, N1BYT, June 1998, pp 35-38.
3. "Designing with Agilent Technologies Isolation Amplifiers" Agilent Technologies, Application Note 1078, Publication No. 5965-5976E, 1999.
4. "Optocouplers for Variable Speed Motor Control Electronics in Consumer Home Appliances" Jamshed N. Khan, Agilent Technologies, White Paper, Publication No. 5980-1297E, 2000.
5. "Motor Drive and Inverter Design Using Optocouplers" Joe Pernyeszi, Mike Walters and Jason Hartlove, Proceeding of PCIM, pp. 397-406, 1995.
6. *Optocoupler Designer's Guide*, Agilent Technologies, Publication No. 5988-4082EN, 2002.
7. "Isolation Amplifiers Compared to Hall Effective Devices for Providing Feedback in Power-Conversion Applications" D. Plant, Proceeding of the Second Small Motor International Conference (SMIC), pp. 353-358, 1996.

www.agilent.com/semiconductors

For product information and a complete list of distributors, please go to our web site.

For technical assistance call:

Americas/Canada: +1 (800) 235-0312 or (916) 788-6763

Europe: +49 (0) 6441 92460

China: 10800 650 0017

Hong Kong: (65) 6756 2394

India, Australia, New Zealand: (65) 6755 1939

Japan: (+81 3) 3335-8152(Domestic/International), or 0120-61-1280(Domestic Only)

Korea: (65) 6755 1989

Singapore, Malaysia, Vietnam, Thailand, Philippines, Indonesia: (65) 6755 2044

Taiwan: (65) 6755 1843

Data subject to change.

Copyright © 2004 Agilent Technologies, Inc.

Obsoletes 5988-9262EN

March 1, 2004

5989-0804EN



Agilent Technologies